

# HS-700EL Technical Data Sheet

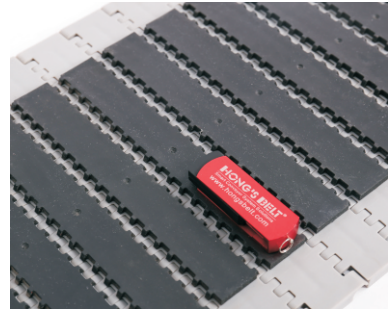
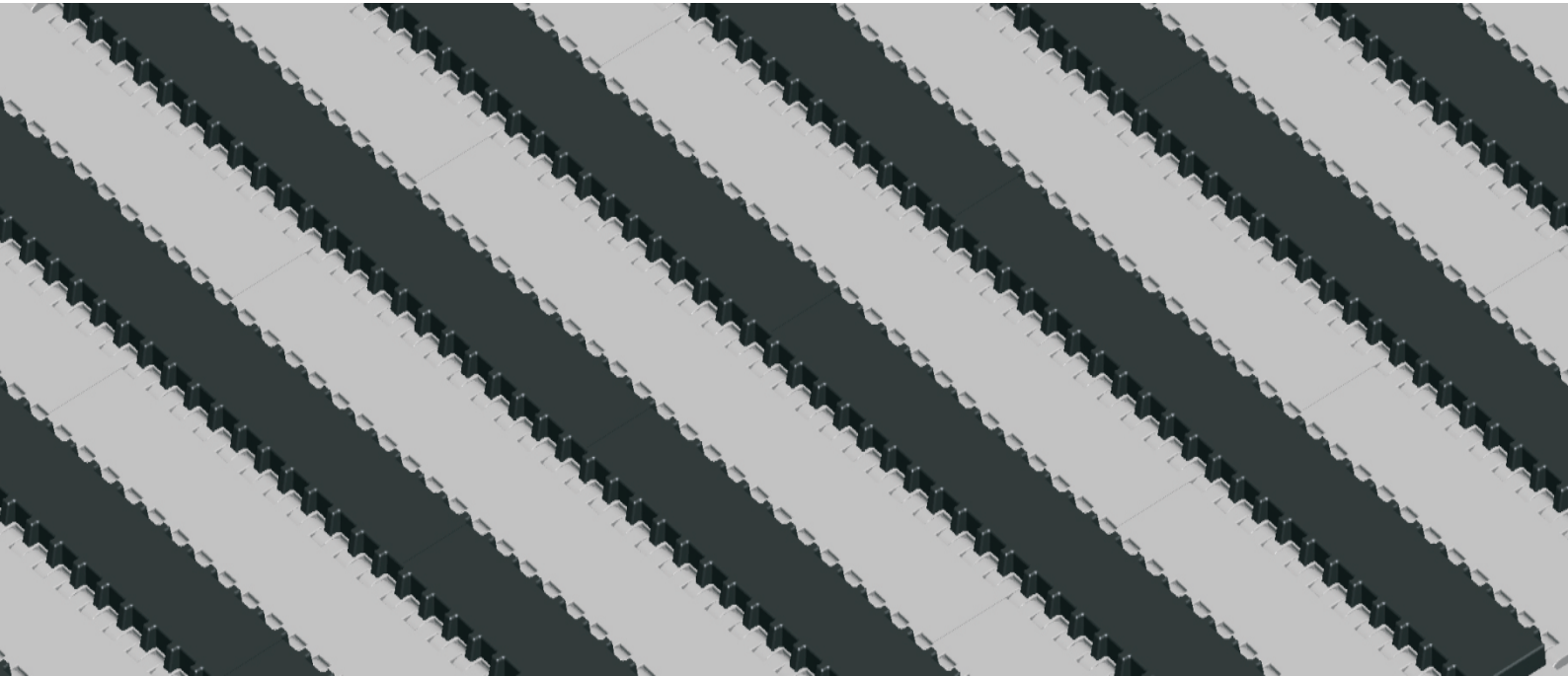

Pitch: 27.2mm Minimum Width: 95mm Open Area: 0% Approved: FDA Rod: Ø 4.9mm Flight: Yes Side Guard: No Curve: No	
--	--

## Data

Belt Material	Belt Strength			Temperature		Belt Weight (Kg / M <sup>2</sup> )
	Straight		Curve	°C (min.)	°C (max.)	
	Kg/M(BW)	N/M(BW)				
Polypropylene	1320	13200	--	1	70	5.7

BW – Belt Width

## Color Table

Polypropylene					Polyethylene					Acetal					Nylon				
W	G	N	DB	B	W	G	N	DB	B	W	G	N	DB	B	W	G	N	DB	B
●	●																		

W-White, G-Gray, N-Nature, DB-Darkbrown, B-Blue

## Friction Table

Belt Material	Friction Wear strips & Products							
	UHMW	HDPE	Steel	Glass	SUS	Plastic	Cardboard	Aluminum
Polypropylene	0.32	0.24	0.15	0.09	0.13	0.08	0.15	0.25
Polyethylene	0.13	0.11	0.26	0.19	0.31	0.16	0.21	0.41
Acetal	0.11	0.09	0.27	0.16	0.26	0.15	0.19	0.28
Nylon	0.18	0.13	0.25	0.16	0.26	0.16	0.19	0.27

SUS – Stainless Steel

## Equivalent type with other Brand

Brand Name	Intralox	UNI	Rexnord	MCC	Habasit	KVP
Series & Type	900	SNB	1005	1000	M2400	610
	1600	CNB	1010		M2500	208
	200	OPB	7700		M2600	
	800		6390			

The above content is only for reference.

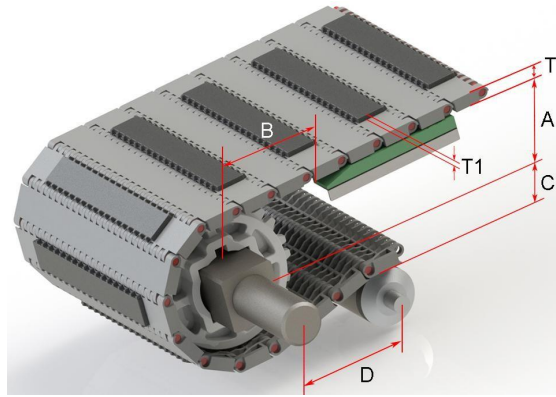

**Conveyor Frame Dimensions**

**Unit : mm**

No. Teeth	A ( Min.)	B ( Min.)	C ( Min.)	D ( Min.)	T	T1
6	21.8	36.15	21.45	200	8.7	3.5
9	35.55	49.9	35.2	200		
10	39.4	53.75	39.05	250		
12	48.4	62.75	48.05	250		
17	71.65	86.0	71.3	300		
18	74.55	88.9	74.2	300		
<b>20 / 20-Split</b>	83.15	97.5	82.8	300		
24	100.55	114.9	100.2	300		

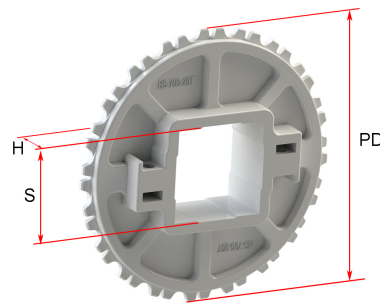
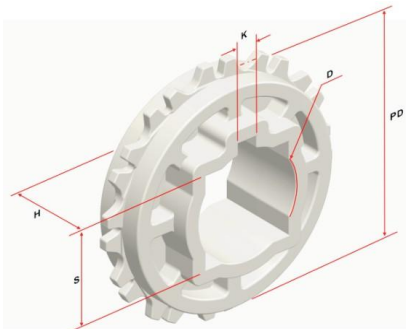

**Sprocket Dimensions**

**Unit: mm**

No. Teeth	PD	S	D	H	K
6	52.3	25.4	--	18.5	--
9	79.8	25.4/38.1	25.4/25.5	21.5	6.35X3.17
10	87.5	25.4/38.1/40.2	25.4/25.5	18.8	6.35X3.17
12	105.5	25.5/30.5/38.5/40.5	25.4/30.5/31.75/38.1 /45.5/47.5	35	8X8
17	152	--	114	25.4	4.5X3.5
18	157.8	38.5/40.5/60.5/63.5	25.4/30.5/31.75/38.1/46/47.5	35	8X8
20	175	38.1/40.2/60.2	25.4/31.75/38.1	35	6.35X3.17
<b>20-Split</b>	175	60.2	31.75	40	6.35X3.17
24	209.8	38.5/40.5	25.4/25.5/30.5/38.1/45.5/47.5	35	8X8